

Data subject to change without prior notice
Edition 04/2020 © 2020 JMG Cranes S.p.A. All rights reserved
Rev. 1 - 04/20

JMG Cranes S.p.A.

Sales & Service Office

Via Bergamo, 142

26100 Cremona - Italy

t +39 0372 1786738

Production Plant

Via Sito Nuovo 14

29010 Sarmato (PC) - Italy

t +39 0523 8486

e info@jmgcranes.com



www.jmgcranes.com



Electric Pick & Carry Cranes



MC 80.06 (metric)

Max Capacity 12,000 kg

Max Capacity Hydraulic Forks
8,000 kg

JMG[®]
movetosolution

MC 80.06

RADIO-REMOTE CONTROL ON DRIVING, STEERING, BOOM MOVEMENTS, WINCH AND OTHER ACCESSORIES

HYDRAULICALLY TELESCOPING PROPORTIONAL TYPE BOOM

EXTENDIBLE REAR GROUP WITH REMOVABLE BALLAST

8 TON HYDRAULIC FORKS

REMOVABLE COUNTERWEIGHTS

180° REAR STEERING



Options :

- HYDRAULIC WINCH
- HYDRAULIC JIB WITH HYDRAULIC EXTENSION
- MANUALLY BENDABLE JIB WITH MANUAL EXTENSION
- NON-MARKING TIRES
- 9 TON HYDRAULIC FORKS
- EXTRA BALLASTS KG 700
- MAN BUCKET
- ATEX CONVERSIONS
- CUSTOMIZED PAINTING



Technical features

Max Capacity kg	12,000
Dimensions mm	3200x1500x1945

Front-wheels drive. 2 electric motors AC 6,5 kW 80V Insulation class H	LMI. Electronic safe load indicator and tilting moment limiter
Total Kg. 13,200 Removable counterweights Kg. 4,100	Automatic braking system on all wheels
80 V - 810 Ah 8 working hours	Fabricated from preformed and welded quality steel plate
Front nr. 4 superelastic 200-15" Rear nr. 2 superelastic 250-15"	+70°/-7°
Rear Steering angle -90°/+90°	Motor driven pump 20 kW - 80 V Insulation class H

Load charts

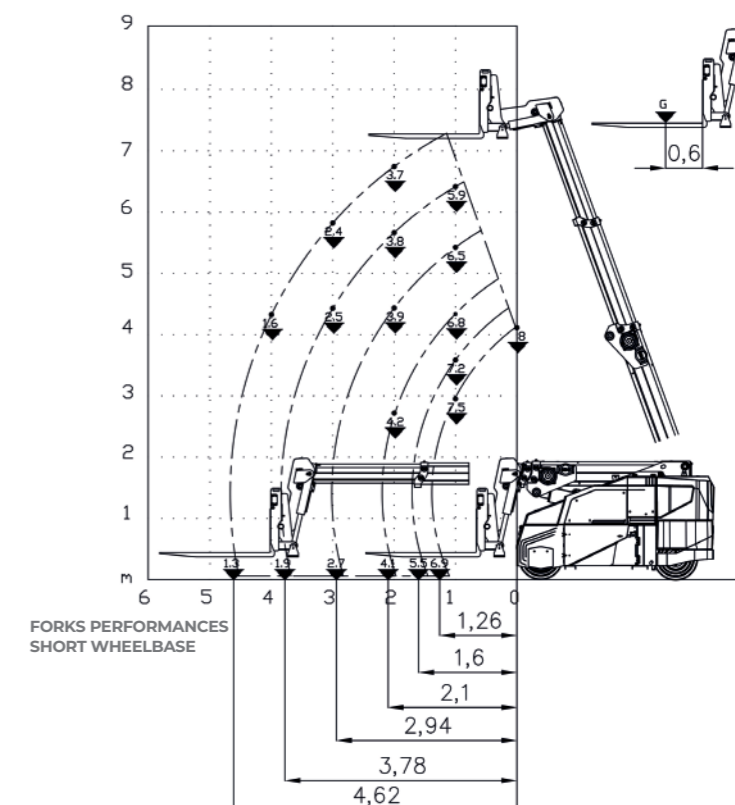
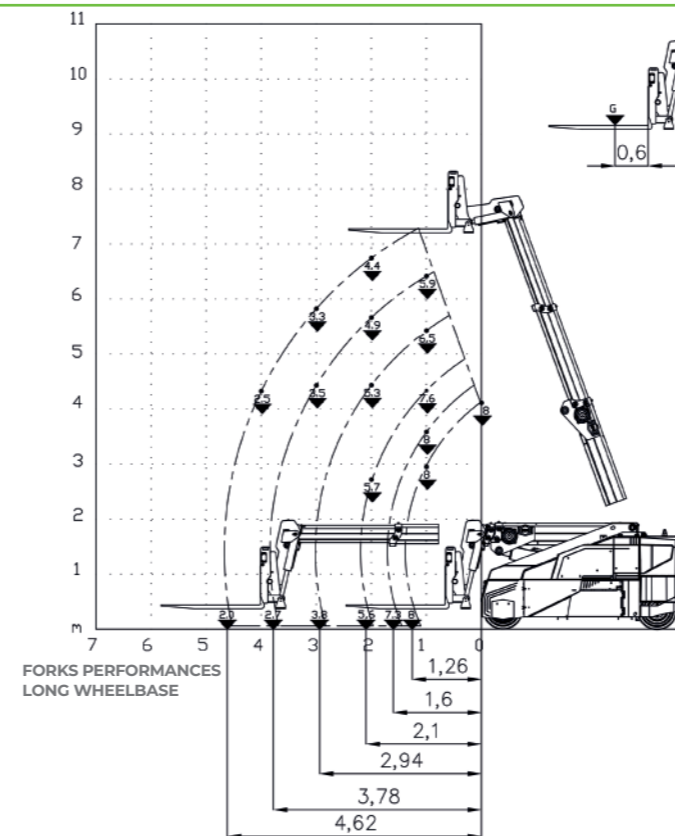
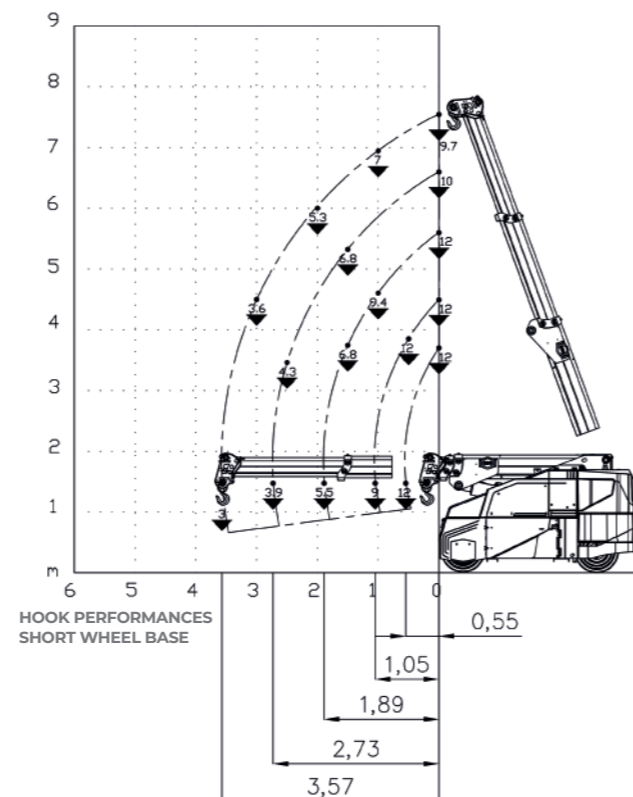
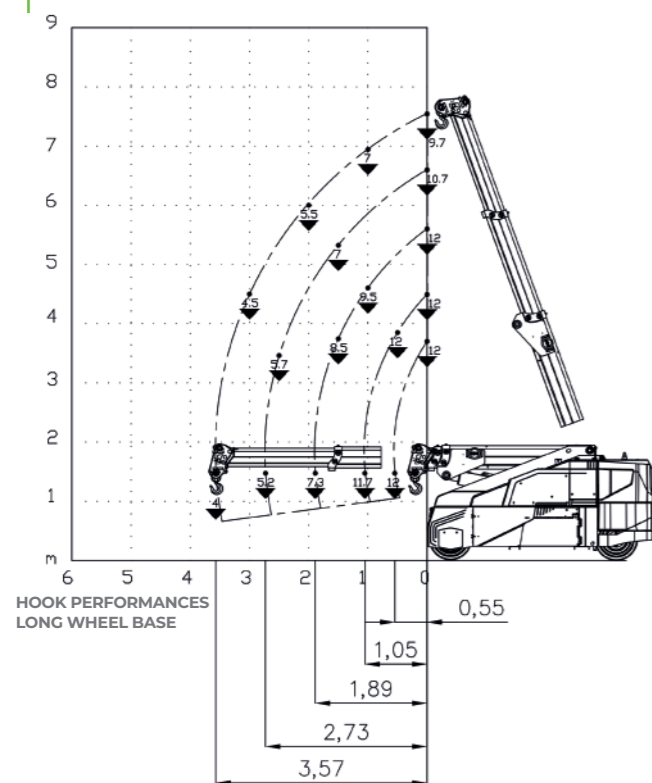

EU Standards CE

	UNI ISO 4301-2: A1
	2006/42 CE-2014/30 UE-2014/35 UE- 2000/14 e and subsequent modifications
	EN 13000:2014 ANSI/ASME B30.5-2011 and subsequent modifications



Dimensions

