

LETS MAKE  
ZERO-EMISSION REAL

RentalMatch.eu

RentalMatch Green Power  
Dealer & Partner of JMG Cranes

Sales & Service Office  
Ecologieweg 16  
3343 LM Hendrik-Ido-Ambacht - Netherlands  
+31 (0) 78 204 92 60  
info@rentalmatch.eu

Gijs van de Graaf  
+31 651855113

Dick van de Graaf  
+31 613214166

Production Plant  
Via Sito Nuovo 14  
29010 Sarmato (PC) - Italy



vca✓

**RentalMatch**  
GREEN POWER

Electric  
Pick & Carry  
Cranes



**MC 100 HYBRID  
(metric)**

Max Capacity 10.000 kg

# MC 100 HYBRID

- ✓ Mobile hybrid crane with diesel generator for battery charging
- ✓ Front-wheels drive with counter rotation
- ✓ Telescopic boom
- ✓ Full electric

### Options:

- Hydraulic winch
- Hydraulic jib with hydraulic Extension
- Manual jib
- Manual extension
- Non-marking tires
- Radio remote control
- Hydraulic forks
- Man bucket
- Atex conversions
- Customized painting



### Technical features

Max Capacity kg	10,000	Front-wheels drive. N°2 electric motors AC 7,5 kW 80V. Insulation class H	LMI. Electronic safe load indicator and tilting moment limiter
	Dimension mm	3955x1845x1970	Total Kg. 10.800
Dimension mm		Front nr. 4 superelastic 250x15/15" Rear nr. 2 superelastic 250x15/15"	Fabricated from preformed and welded quality steel plate
	Dimension mm	Rear steering Steering angle -90/+90	+63°/-10°
			Motor driven pump 20 kW- 80 V AC

### Load charts

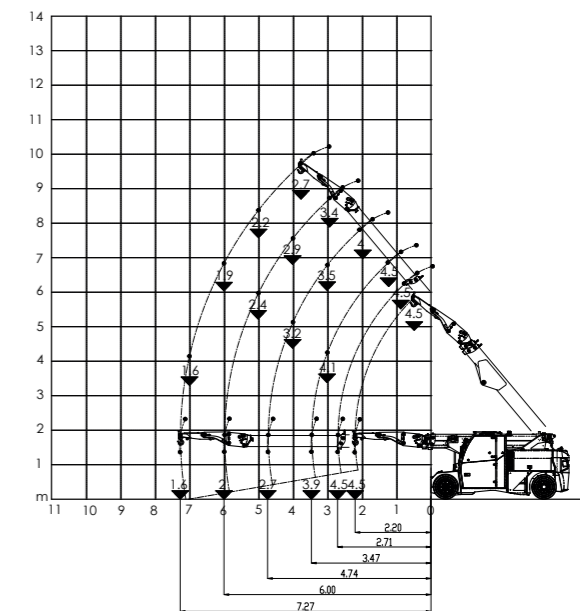
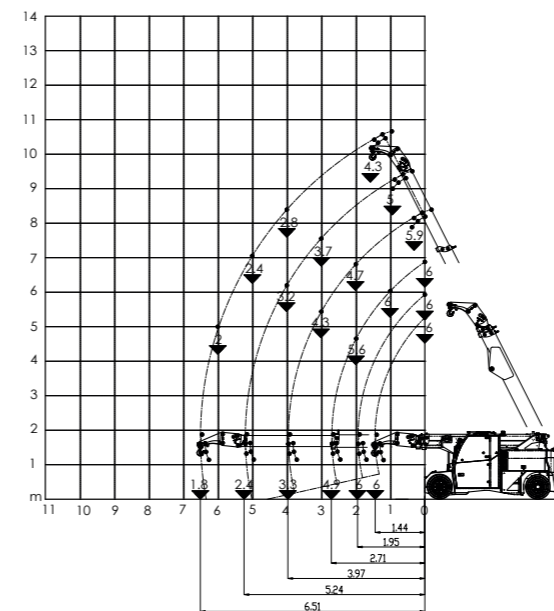
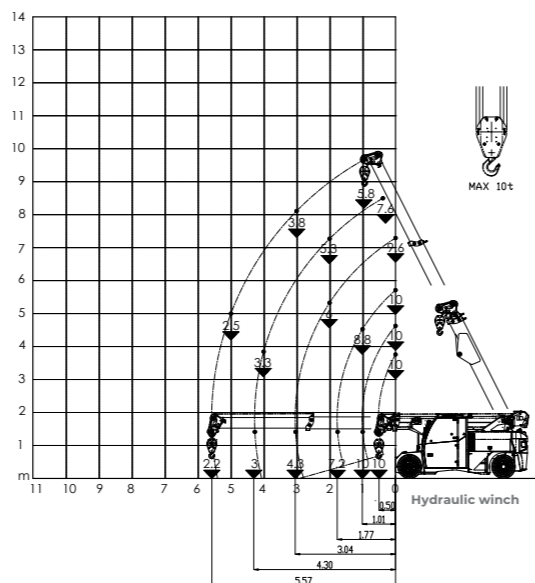

### EU Standards CE

	UNI ISO 4301-2: A1
	2006/42 CE-2014/30 UE-2014/35 UE- 2000/14 and subsequent modifications
	EN 13000:2014 ANSI/ASME B30.5-2011 and subsequent modifications

### Dimensions

