

LETS MAKE
ZERO-EMISSION REAL

RentalMatch.eu

RentalMatch Green Power
Dealer & Partner of JMG Cranes

Sales & Service Office
Ecologieweg 16
3343 LM Hendrik-Ido-Ambacht - Netherlands
+31 (0) 78 204 92 60
info@rentalmatch.eu

Gijs van de Graaf
+31 651855113

Dick van de Graaf
+31 613214166

Production Plant
Via Sito Nuovo 14
29010 Sarmato (PC) - Italy



vca✓

**RentalMatch**
GREEN POWER

Electric
Pick & Carry
Cranes



MC 120 (metric)
Max Capacity 12,000 kg

MC 120

- ✓ Telescopic boom
- ✓ Front-wheels drive with counter rotation
- ✓ Removable counterweights

Options:

- Hydraulic winch
- Hydraulic jib
- Hydraulic extension
- Manual jib
- Manual extension
- Non-marking tires
- Radio remote control
- Hydraulic forks
- Man basket
- Atex conversions
- Customized painting



Technical features

Max Capacity kg	12,000	Front-wheels drive. 2 electric motors AC 7,5 kW 80V Insulation class H	LMI. Electronic safe load indicator and tilting moment limiter
		Total Kg. 13,750 Removable counterweights Kg. 3,000	Hydraulically foot controlled service brake on all wheels, hydraulically automatic or button controlled parking brake on front wheels
Dimension mm	4020x1950x2000	80 V - 920 Ah 8 working hours	Fabricated from preformed and welded quality steel plate
		Front nr. 4 superelastic 300-15" Rear nr. 2 superelastic 250-15"	+60°/-10°
		Rear Steering angle -90°/+90°	Motor driven pump 1x16 kW-80 V AC

Load charts

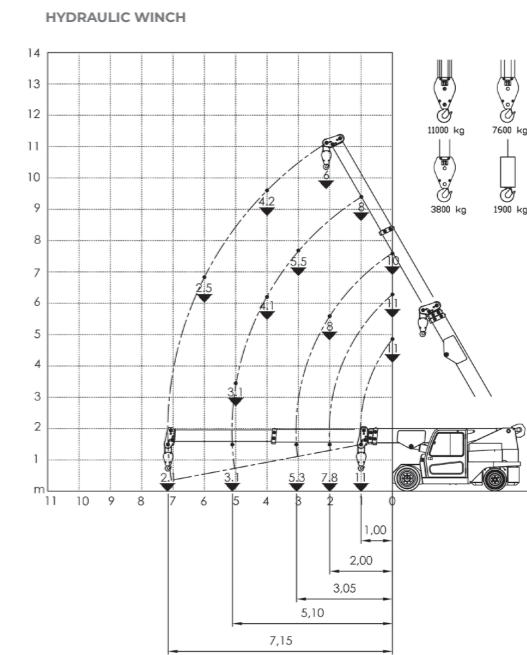
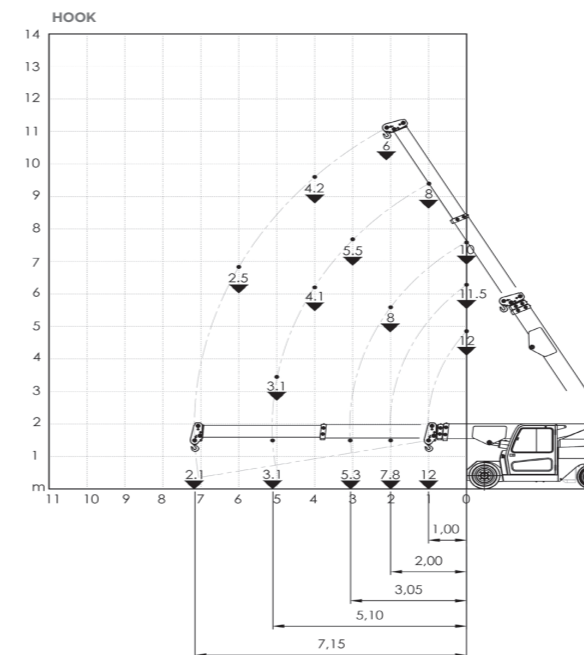

EU Standards CE

	UNI ISO 4301-1: A1
	2006/42 CE-2014/30 UE-2014/35 UE- 2000/14 and subsequent modifications
	EN 13000:2014 ANSI/ASME B30.5-2011 and subsequent modifications

Dimensions

